

Series		Description	Size									Mounting		Page
Parker	Denison		1/4	3/8	1/2	3/4	1	06	10	16	Subplate	Screw-in		
		Parker Standard DIN / ISO												
		<b>Throttle valves, manual adjustment</b>												
MVI	–		•	•	•	•	•					•	•	5-3
NS	–		•	•	•	•	•					•		5-5
FS	–	With free return flow	•	•	•	•	•					•		5-7
		<b>Flow control valves, manual adjustment</b>												
PC*MS	–		•	•	•	•	•					•		5-9
GFG2	–							•				•		5-11
–	2F1C								•	•		•		5-15
		<b>Flow control valves, proportional adjustment</b>												
DUR*L	–							•				•		5-21
		<b>Accessories</b>												
		Plug-in connectors												5-25

More flow valves are presented in the following chapters:

- Chapter 7: Sandwich Valves
- Chapter 8: Slip-In Cartridge Valves
- Chapter 9: SAE Flange Valves
- Chapter 10: Valves for Pipe Mounting



Manatrol needle valve with steel body as screw-in valve for block insertion, optionally with a 30° taper-fine, V-notch or micro-fine rectangular slot. The form of the metering opening influences the accuracy of the flow adjustment, which is pressure and viscosity dependent. The needle is made of stainless steel and fits into a ring gap in the valve cartridge. For details of cutting tools for reaming the block bore, see 'Accessories' at the end of this chapter.

**Characteristic values**

Size	Operating press. [bar]	Flow [l/min] Δp 10bar	Max. orifice area [cm <sup>2</sup> ]	Kv factor valve	Weight [kg]
400	350	25	0.14	6.3	0.18
600	350	65	0.37	18.5	0.32
800	350	105	0.55	27.5	0.59
1200	350	160	0.90	45.7	0.95
<b>Needle size</b>					
400-2		11	0.52		
400-3		2	0.012		

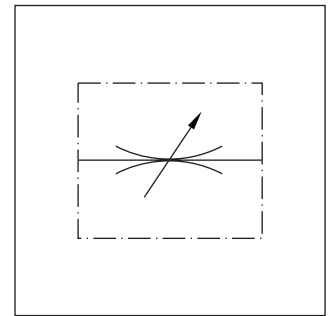
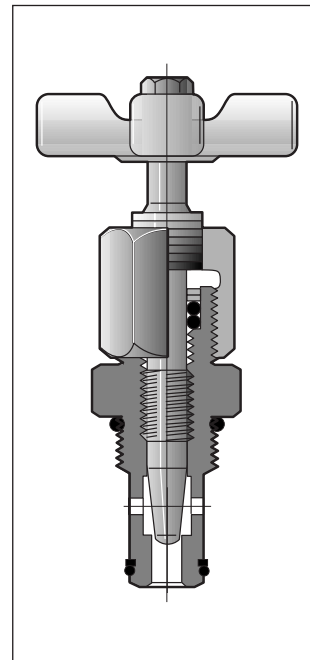

**5**

$$\text{Flow rate } Q \text{ [l/min]} = K_v \cdot \sqrt{\frac{\Delta p}{\gamma}}$$

Kv see table  
 Δp [bar]  
 γ [kg/dm<sup>3</sup>] = specific gravity of fluid  
 (γ for mineral oil = 0.85 – 0.9)

**Δp/Q curves**

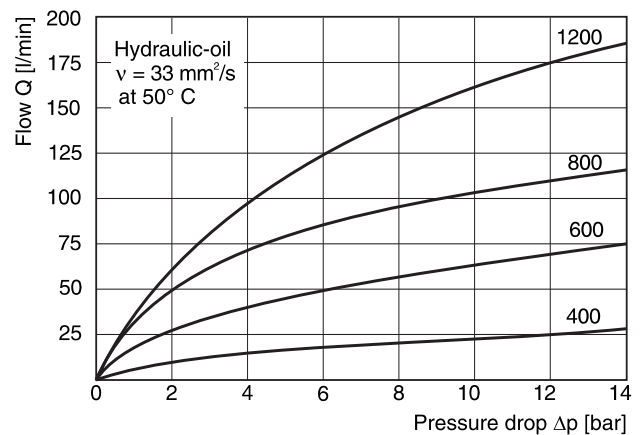

**Ordering code**

<b>MVI</b>		<b>S</b>		
Cartridge-type needle valve	Size and screw-in threads	Steel body	Needle	Seal

Code	Size	Threads
400	1/4"	3/4 - 16 UNF-2B
600	3/8"	7/8 - 14 UNF-2B
800	1/2"	1 1/16 - 12 UN-2B
1200	3/4"	1 5/16 - 12 UN-2B

Code	Seal
omit	<b>NBR</b>
V	FPM

Code	Needle
omit	<b>Standard 30° taper</b>
2*	Fine V-notch
3*	Micro-fine slotted

**Bold letters = Short-term availability**

\* only for size 400

**Threaded cartridge valve**

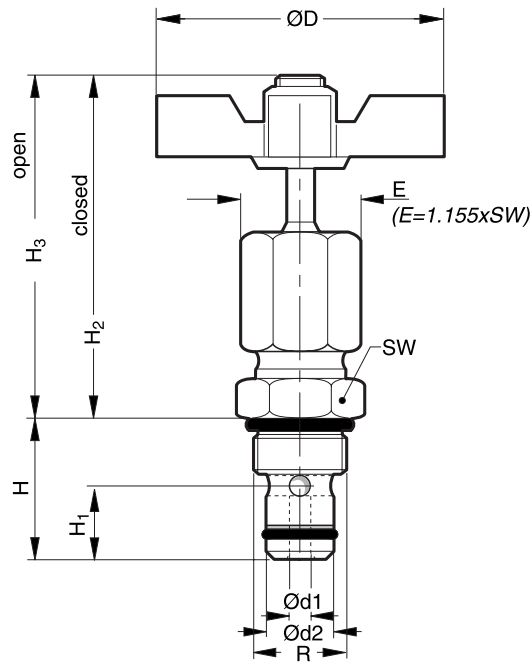

Size	H	H3	H2	H1	Ød1	Ød2	R (Threads)	ØD	SW
MVI 400	25.4	65	60	10.9	4.6	14.22	3/4 - 16 UNF-2	51	22.1
MVI 600	30	81	73	13.5	7.9	15.8	7/8 - 14 UNF-2	64	25.4
MVI 800	39.6	91	79	15.2	9.4	20.55	1 1/16 - 12 UN-2	83	31.8
MVI 1200	43.4	102	88	19.1	11.7	26.92	1 5/16 - 12 UN-2	98	38.1

**Mounting cavity**

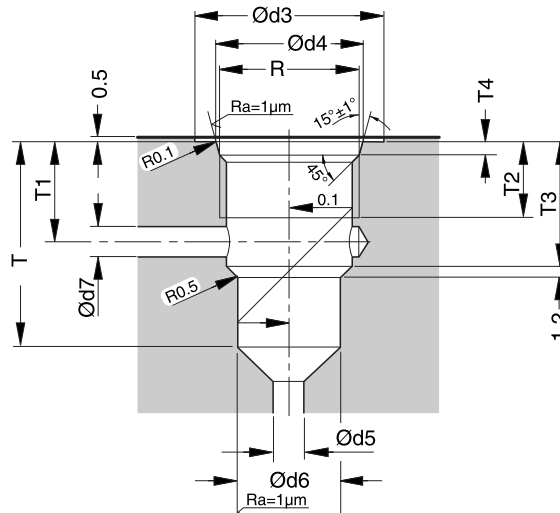

Size	Ød3	Ød4 <sup>+0.12</sup>	Ød5 (min)	Ød6 <sup>+0.05</sup>	Ød7	T4 <sup>+0.38</sup>	T2	T3	T	T1
MVI 400	26	20.6	5.3	14.275	5.3	2.54	15	17.8	27	14.2
MVI 600	30	23.93	8.1	15.85	8.1	2.54	17	21.6	32	16.5
MVI 800	37	29.16	10.2	20.6	10.2	3.3	19	30	42	24.1
MVI 1200	44	35.54	12.7	26.975	12.7	3.3	19	31.8	46	24.6

Manatrol shut-off and metering valves with 2 stage needle cone. Fine adjustment for the first stage can be achieved with 3 rotations of the adjustment knob. The second stage with normal throttle characteristics is achieved with 3 further rotations.

A cylindrical needle with a rectangular slot is provided to reduce the viscosity effect for sizes 400 and 600. The flow is dependent on pressure and viscosity.

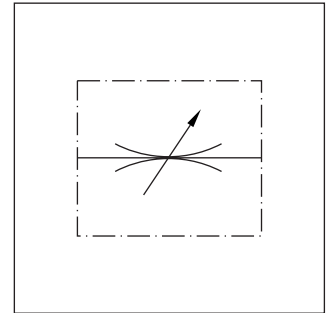

**Characteristic values**

(only for standard 2 stage needle)

Size	Press. [bar]		Flow [l/min] Δp 10bar	Max. cross-section [cm²]	Kv factor valve open	Weight [kg]
	steel	brass				
400	210	140	25	0.13	6.3	0.4
600	210	140	40	0.22	11.2	0.6
800	210	140	50	0.28	13.9	1.0
1200	210	140	120	0.70	35.4	2.0
1600	210	35	250	1.48	75	4.0

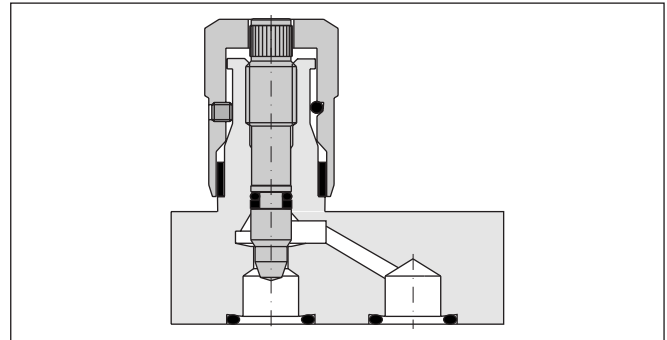

**5**

Flow rate Q [l/min] =  $K_v \cdot \sqrt{\frac{\Delta p}{\gamma}}$

Kv from the table  
 Δp [bar]  
 γ [kg/dm³] = specific weight of the medium  
 (γ for mineral oil = 0.85 – 0.9)

**Δp/Q curves**

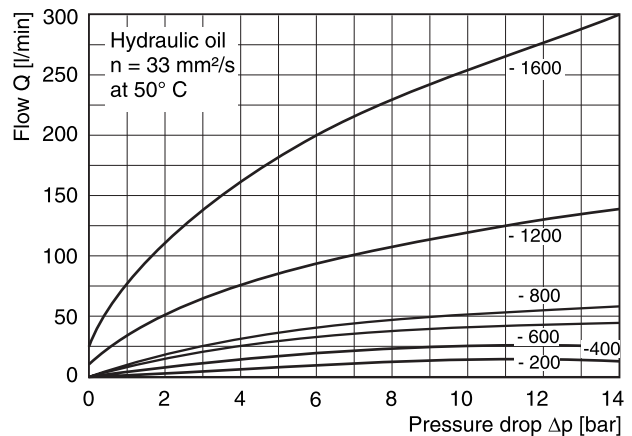

**Ordering code**

<b>N</b>	<b>S</b>		<b>S</b>			
Needle valve	Manifold mounting	Size	Steel body	Needle	Clamping screw	Seal

Code	Size						
400	400					Code	Seal
600	600					omit	<b>NBR</b>
800	800					V	FPM
1200	1200					Code	Clamping screw
1600	1600					omit	<b>Hexagon socket</b>
						F	With knurled knob

Code	Needle
omit	<b>Standard 2 stage needle</b>
4*	Micro-fine hollow needle with slot

**Bold letters = Short-term availability**

\* only for sizes 400 to 600

Dimensions

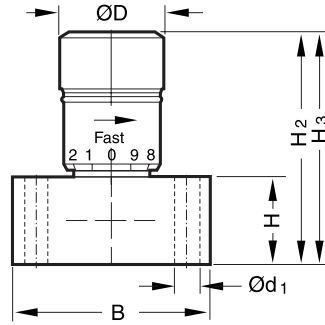
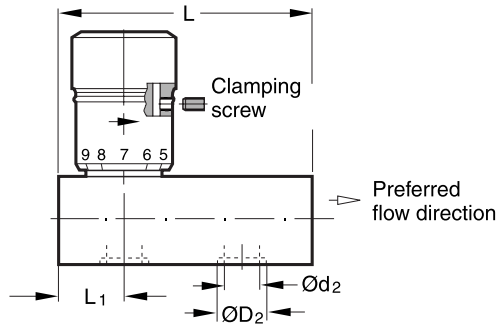

H<sub>2</sub> = closed  
H<sub>3</sub> = open

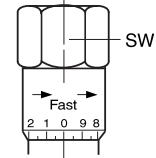

Hexagon adjusting knob, standard for size 1600

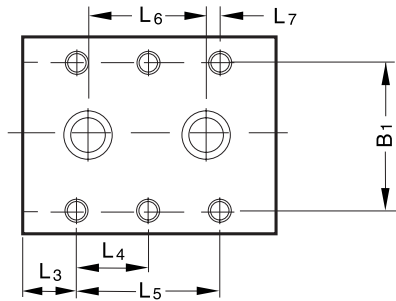

5

Size	L	L5	L4	L3	L7	L6	ØD2	Ød2	B1	B	H3	H2	H	Ød1	ØD	SW	L1
400	47.5	34.8	-	6.4	4.5	25.4	13.3	7	33.5	44.5	55	50	21	6.8	21	-	11
600	51	33.3	-	8.6	4.1	25.4	16	10	38.1	51	67	61	25.4	7	25	-	13
800	75	38.1	-	18.5	4.1	30	19.1	13	44.5	57.5	77	70	25.4	7	30	-	23
1200	93.5	76.2	38.1	8.6	11.2	54.4	24	17	54	70	95	80	29	9.5	35	-	20
1600	111	95.3	47.5	7.9	19	57.2	32	22	60.2	76.5	140	123	45	9.5	-	47.8	27

Manatrol throttle check valves of series FS allow the adjustment of the flow for a defined direction.

A 2 stage needle allows for very exact setting of smaller flow rates with the first 3 rotations of the adjustment knob. After 3 more rotations, the valve is completely open. The valve setting can be locked by a locking screw.

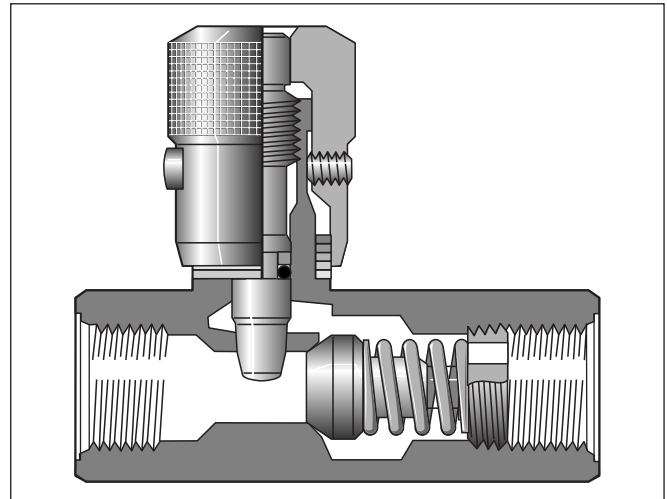
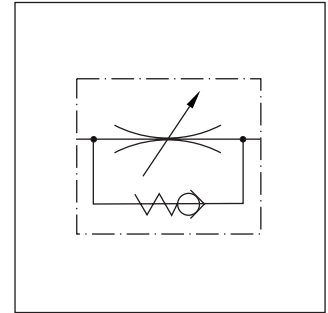

**5**

$$\text{Flow rate } Q \text{ [l/min]} = K_v \cdot \sqrt{\frac{\Delta p}{\gamma}}$$

$K_v$  from the table  
 $\Delta p$  [bar]  
 $\gamma$  [kg/dm<sup>3</sup>] = specific gravity of fluid  
 ( $\gamma$  for mineral oil = 0.85 – 0.9)

**Characteristic values**

Size	Pressure [bar]	Max. flow [l/min Δp10bar]	Opening [cm <sup>2</sup> ]	Check Kv factor	Throttle surface [cm <sup>2</sup> ]	Throttle v. open Kv factor	Weight [kg]
400	210	25	0.37	18.6	0.13	6.3	0.23
600	210	40	0.62	30.4	0.22	11.2	0.31
800	210	50	0.86	43.4	0.28	14	0.67
1200	210	120	1.18	60	0.70	35.4	1.17
1600	210	250	2.23	111	1.48	75	2.31

**Ordering code**

<b>F</b>	<b>S</b>		<b>S</b>			
Throttle and check valve	Subplate mounting	Size	Steel body	Needle	Clamping screw	Seal

Code	Size			Code	Seal
400	400			omit	<b>NBR</b>
600	600			V	FPM
800	800				
1200	1200			Code	Clamping screw
1600	1600			omit	<b>Hexagon socket</b>
				F	With knurled knob

Code	Needle
omit	<b>Standard 2 stage needle</b>
4*	Micro-fine hollow needle with slot

**Bold letters = Short-term availability**

\* only for sizes 400 to 600



Manatrol 2 way flow control valves for pressure compensated regulation of the flow. As a consequence of pressure changes, the set value can vary by ± 5% within the tolerance range. Changes in viscosity and in temperature have the same effect and are to be observed.

The series PCCMS is additionally equipped with a built-in check valve for the return flow.

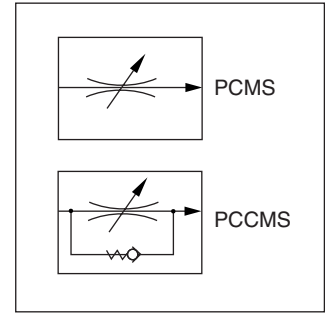

**Characteristic values**

Size	Max. press. [bar]	Flow control		Check valve		Weight [kg]
		Q* [l/min]	Δp [bar]	Q <sub>max</sub> [l/min]	Δp [bar]	
400	210	1 - 10	7	20	3	0.77
600	210	2 - 25	7	30	3	1.23
800	210	6 - 60	11	75	8	2.50
1200	210	10 - 100	11	130	8	3.18
1600	210	19 - 190	11	250	10	7.41

\* Min. and max. flow rate

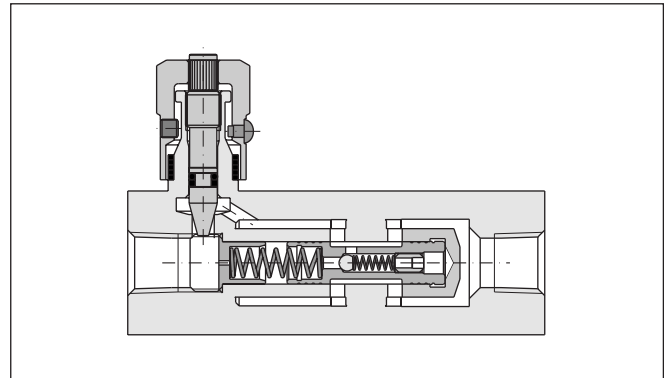

**5**

**Ordering code**

<b>PC</b>		<b>M</b>	<b>S</b>		<b>S</b>			
Pressure compens. flow control valve	Check valve	Manual adjustment	Subplate mounting	Size	Steel body	Clamping screw	Seal	Design series (not required for ordering)

Code	Check valve						
omit	<b>Without check valve</b>					Code	Seal
C	With check valve					omit	<b>NBR</b>
						V	FPM

  

Code	Nominal size						
400	400					Code	Clamping screw
<b>600</b>	<b>600</b>					omit	<b>Hexagon socket</b>
<b>800</b>	<b>800</b>					F	With knurled knob
1200	1200						
1600	1600						

  

**Bold letters = Short-term availability**

Controlled flow vs. pressure drop

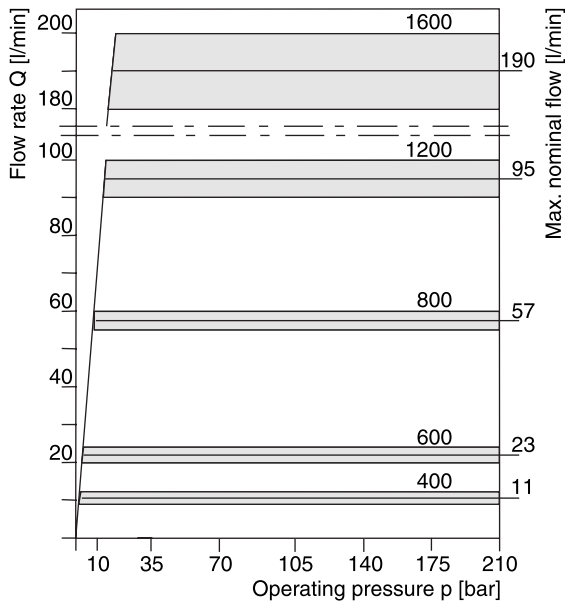

Reverse flow vs. pressure drop at minimum and maximum settings

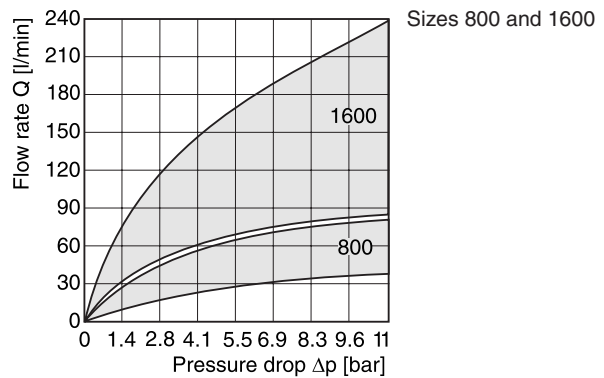
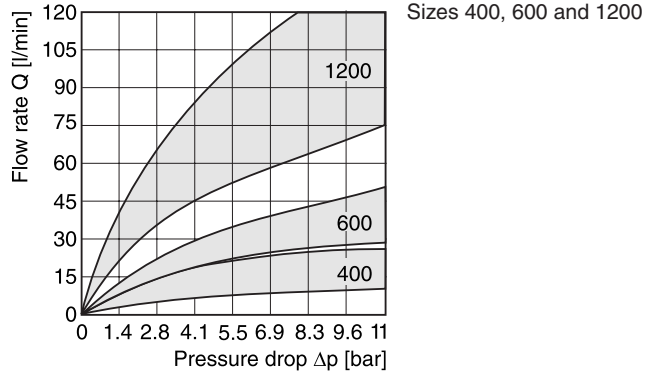

The curves refer to hydraulic oil of 33 cSt / 50°C.

Dimensions

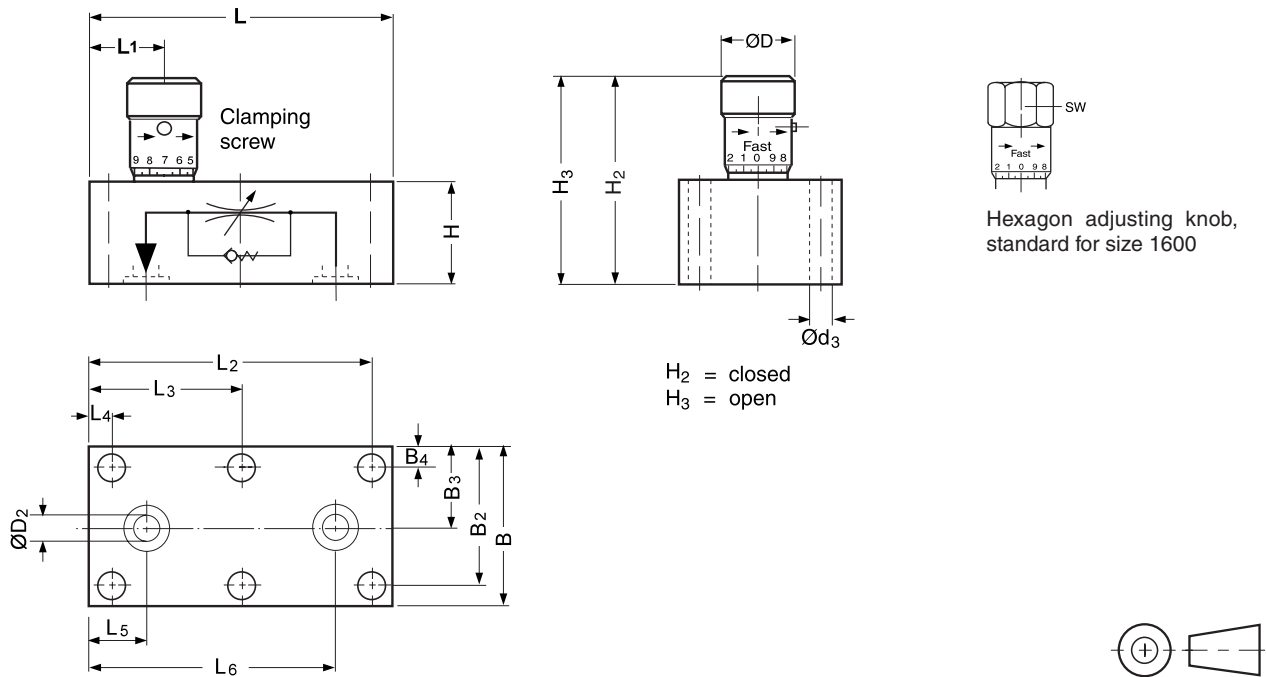

Size	B	B2	B3	B4	L4	L5	L6	L2	L	H	Ød3	H3	H2	ØD2	ØD	L1	L3	SW
400	45	38.9	22.4	5.6	6.4	15.7	69.9	79.2	86	29	6.8	63	58	7.1	21	21	-	-
600	51	44.5	25.4	6.4	6.4	16.8	84.8	95.3	102	32	7	73	68	8.6	25	25	-	-
800	58	50.8	28.4	6.4	6.7	19.1	98.6	111.3	117	45	7	103	95	11.9	30	45	-	-
1200	70	62.0	35.1	7.9	9.7	25.4	117.3	133.4	143	57	9.5	129	116	16.8	35	41	71.4	-
1600	76	68.3	38.1	7.9	12.7	31.7	139.7	158.7	172	70	9.5	175	158	22.3	-	49	85.8	47.8

PCMS\_UK.INDD CM

5

**Characteristics**

2 way flow control valves are used to provide pressure compensated flow. The valve design also compensates temperature and viscosity variations to a certain extent. Optionally the flow from A to B can be blocked by external pilot pressure applied to port P (option X). This can be used to avoid unintended initial movements of actuators. The GFG is optionally equipped with a built-in check valve for the return flow.

**Design**

The 2 way flow control valves are fitted with a triangular flow restrictor and a subsequent pressure compensator. The setting of the flow rate can be locked by a key lock in the adjusting knob against unauthorised adjustment (option C).

**Function**

The fluid enters through port A through the flow restrictor. Downstream of the flow restrictor the pressure compensator is located. The control edges are provided by four radial bores in the poppet, which are fully open to port B in the neutral position.

This can cause a short non-compensated flow when the valve is initialized.

Optionally the compensator spool can be held in closed position by external pilot pressure in port P (option X).

The flow adjustment is done via the flow resistor which is adjusted by the hand knob. The adjusting angle of the hand knob is 270°.

**Features**

- Flow rate independent of pressure, temperature and viscosity
- Available for 7 different flow rates
- Good fine adjustment
- Optional reverse flow check valve
- Turn knob with key lock (option C)

**Note**

Rectifier plate see 'Accessories' at the end of this chapter.

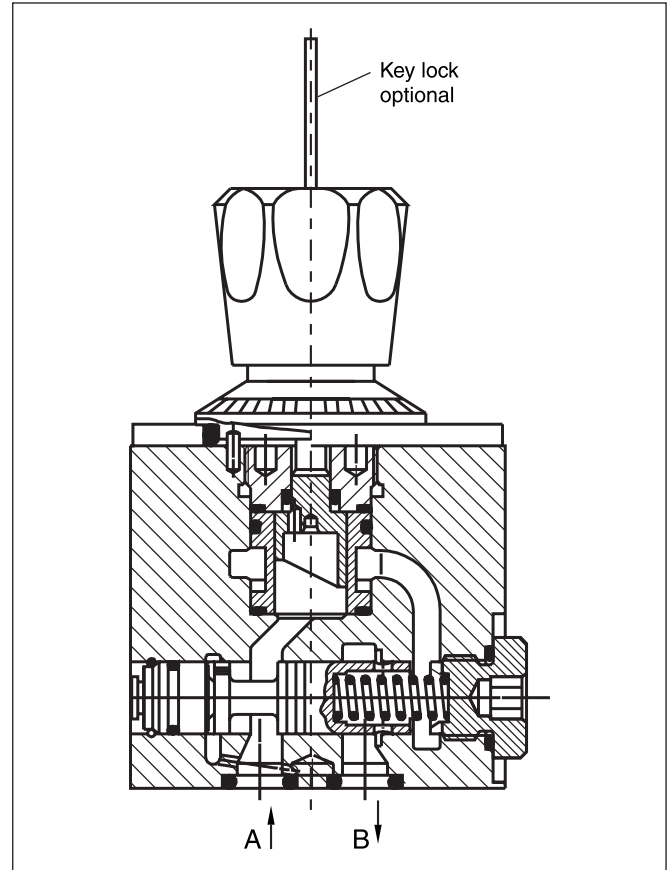
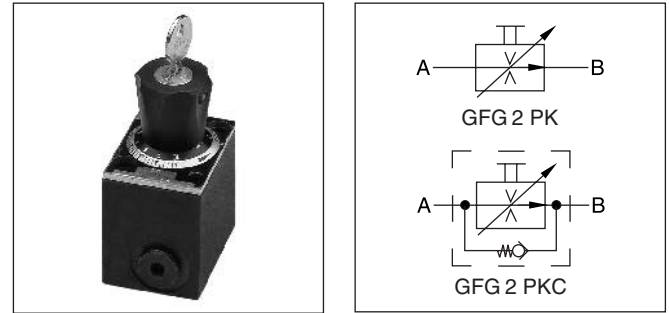

Technical Data / Ordering Code

Technical data

Design	Orifice, infinitely variable, pressure-compensated
Actuator	Manual flow rate adjustment
Mounting type	ISO 6263 code: ISO 6263-AB-03-4-B
Mounting position	unrestricted
Weight	[kg] 1.1 (without subplate)
Fluid temperature	[°C] Max. 70
Ambient temperature	[°C] -25...+50
Viscosity range	[cSt] / [mm²/s] 2.8...400
Filtering	[µm] 10 (Q < 0.5l/min), 25 (Q > 0.5l/min)
Min. pressure difference	[bar] 5 (GFG*1.6/3.2), 8.5 (GFG*6.3/12/18)
Operating pressure	[bar] A; B = 315 , P = 5 (GFG*, GFG*C), A, B, P = 160 (GFG*X)
Effect of pressure on Q <sub>max</sub> at p = 160 bar	[%] ± 2 (GFG*1.6/3.2/6.3/12), ± 2.5 (GFG*18)
Flow direction	Flow control function
A → B	Throttle function or free flow through check valve
B → A	

5

Ordering code

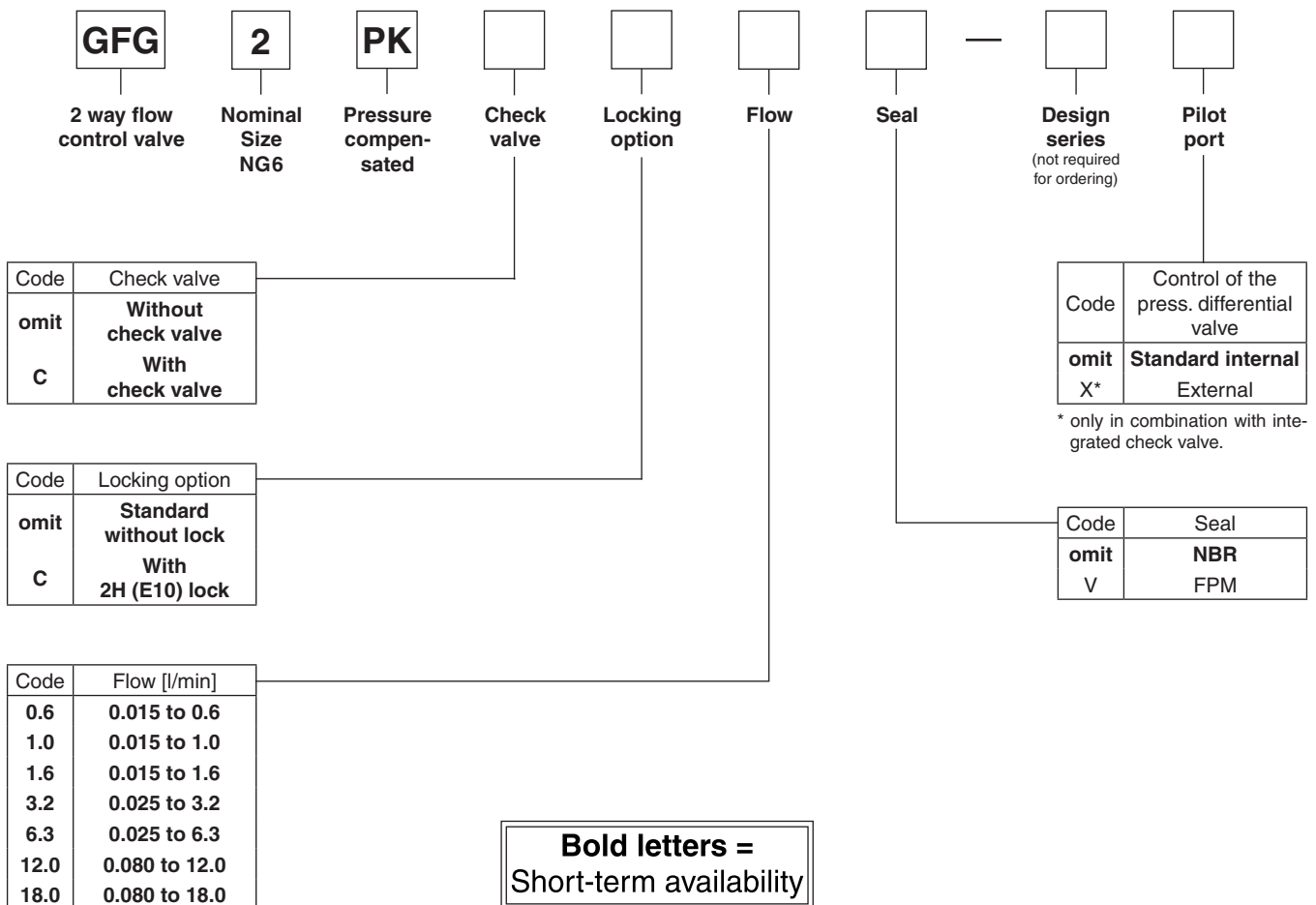

Performance curves

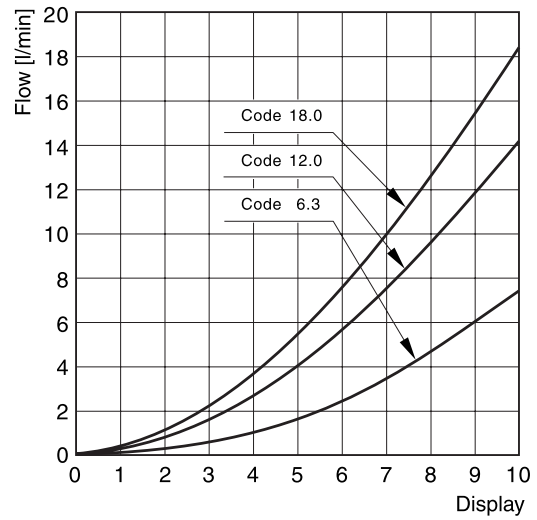
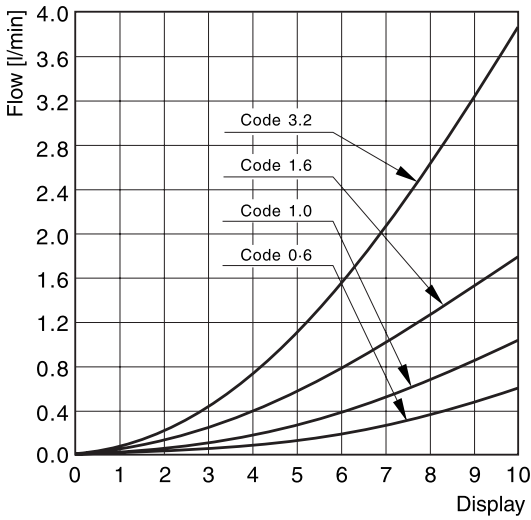

Changes in pressure cause a change of pre-set flow rate.  
Flow rate deviations a  $Q_{max} : \pm 2\%$

Dimensions

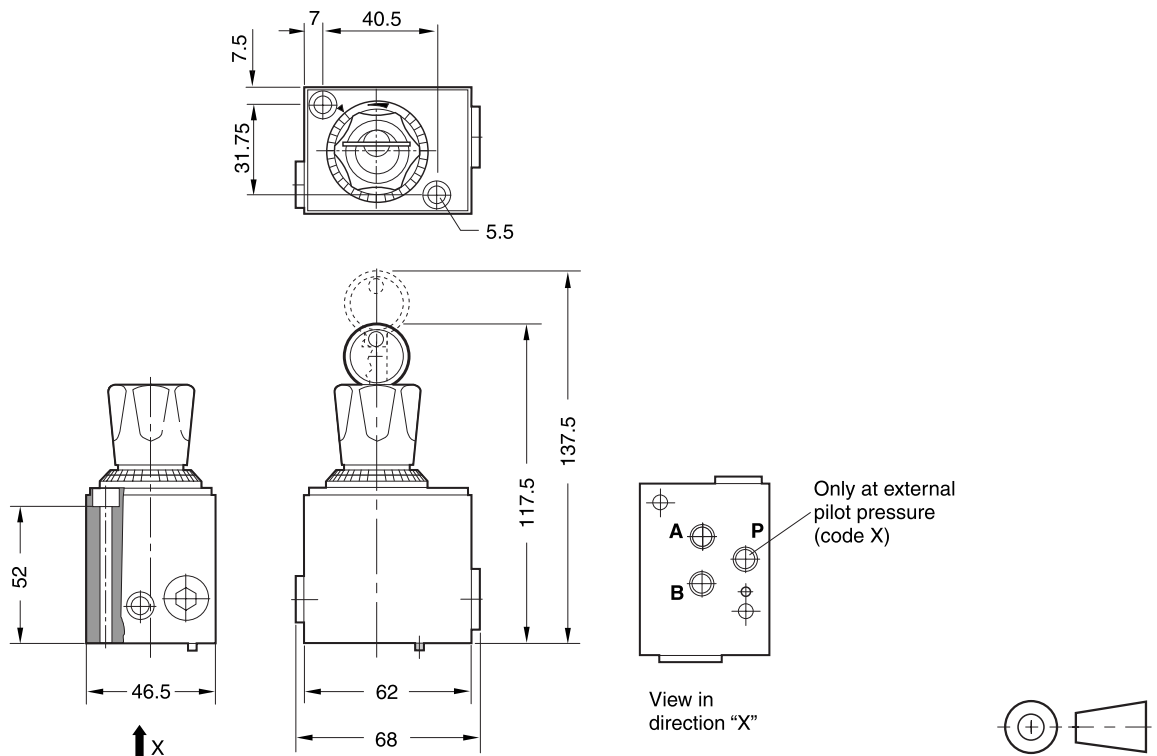

Bolt kits (Cylinder head DIN 912-12.9 not included)

Nom. size Valve	Valve model	Quantity	Tightening torque [Nm]	Valve without rectifier plate		Valve with rectifier plate	
				Dimensions	Order No.	Dimensions	Order No.
NG6	GFG2	2	8.1Nm	2xM5x60	BK380	2xM5x100	BK466

O-rings for sealing the connecting surface

Nom. size Valve	Valve model	Ports	Dimensions Ø-inner x cord thickness	Quantity	Seal kits	
					NBR	FPM
NG6	GFG2	A and B	9x1.5	3	SK-GFG2	SK-GFG2 FPM

GFG2\_UK.INDD CM



**Characteristics**

2 way flow control valves series 2F1C provide pressure and viscosity compensated flow from port A to port B. The counter direction is blocked (standard) or can be open via an integral reverse flow check valve (optional).

**Function**

The compensator spool is located in front of the metering spool. The metering spool is closed in the neutral position to avoid undesired initial actuator motion. The oil flow to open the metering spool has to pass a needle valve (not shown in the sectional drawing). The needle valve can be adjusted from the front panel to set the response time of the 2F1C.

The metering spool is adjusted by the main control knob. The key lock has three positions:

- Lock: Adjustment is locked.
- Adjust: Full adjustment is permitted.
- Trim: Fine adjustment of +/- 5% is possible.

**Features**

- 2 way flow control valve
- Subplate mounting according to ISO 6263
- Excellent fine adjustment
- Adjustable response time
- Closed in neutral position
- Optional reverse flow check valve
- 2 sizes, NG10 (3/8"), NG16 (3/4")

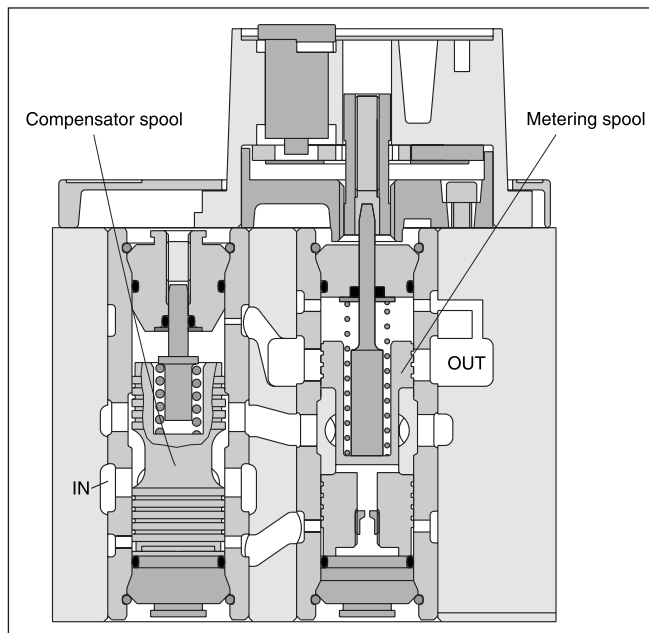
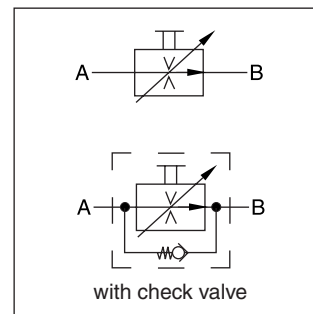

5

Technical Data / Ordering Code

Technical data

Design	Orifice, infinitely variable, pressure-compensated	
Actuator	Manual flow rate adjustment	
Mounting type	ISO 6263	
Mounting position	unrestricted	
Weight	[kg]	6.0 (2F1C02), 9.0 (2F1C03)
Fluid temperature	[°C]	Max. 70
Ambient temperature	[°C]	-25...+50
Viscosity range	[cSt] / [mm²/s]	2.8...400
Filtering	[µm]	15
Min. pressure difference	[bar]	see diagram
Max. operating pressure		
		<b>2F1C02</b> <b>2F1C03</b>
	Port A	[bar] 14...280
	Port B	[bar] 0...270
Flow direction		
A → B		
B → A		
	Flow control function blocked or free flow through check valve	

5

Ordering code

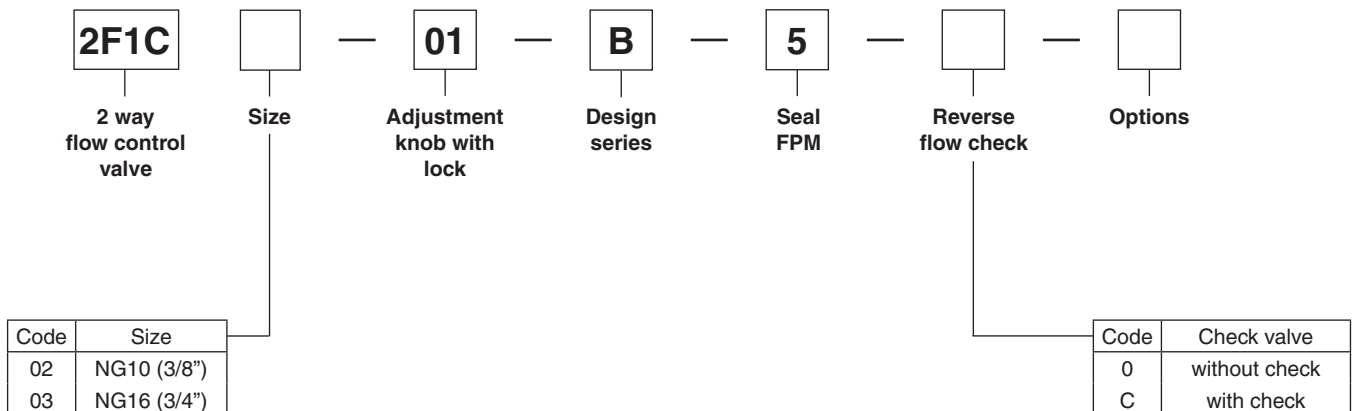

**Performance curves**

**Flow / knob adjustment characteristics at 210 bar**

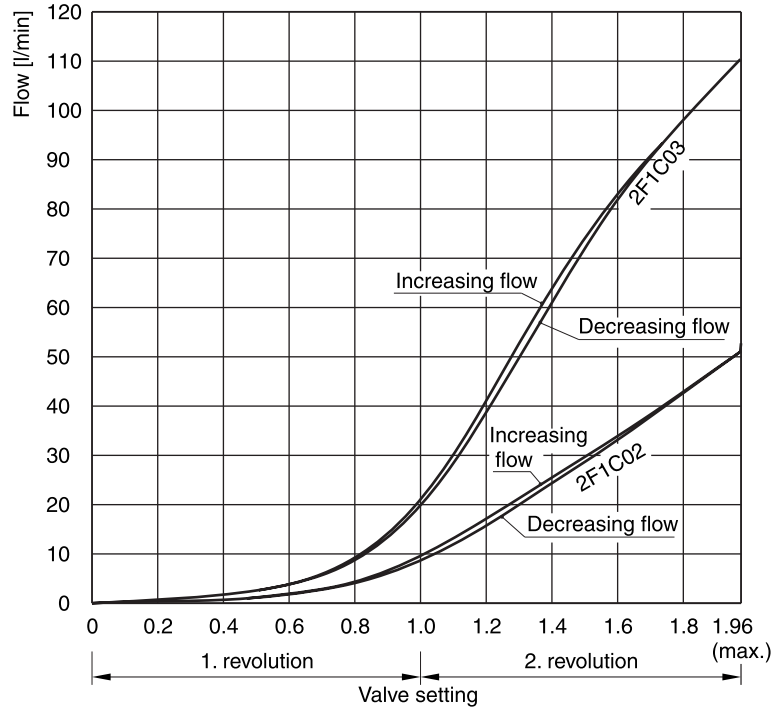

**5**

**Flow / pressure drop curves**

Constant inlet pressure – variable outlet pressure

**2F1C02**

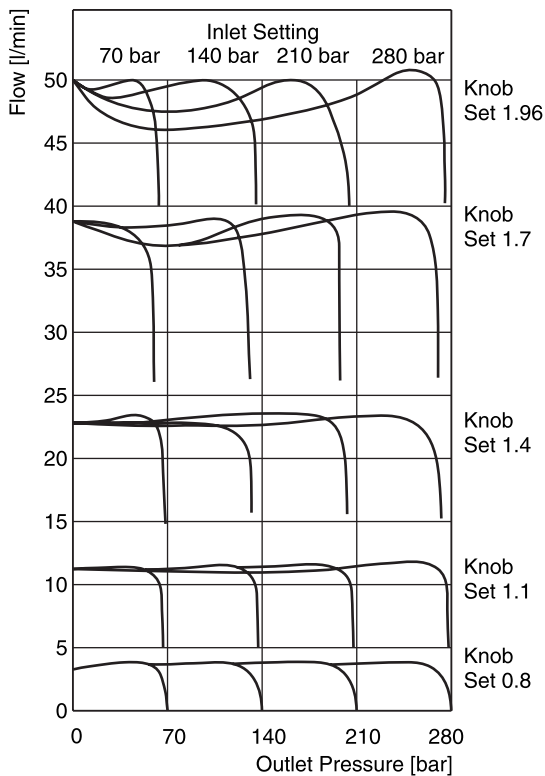

**2F1C03**

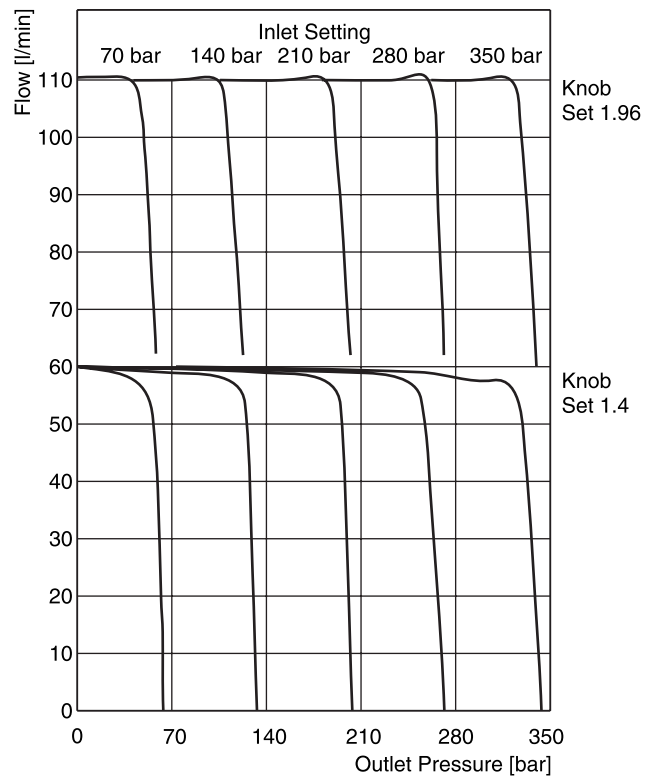

Fluid viscosity 40 cSt at 50°C

2F1C\_UK.INDD CM

**$\Delta p/Q$  performance curves**

for reverse flow direction

2F1C02 at 280 bar

2F1C03 at 350 bar

**5**

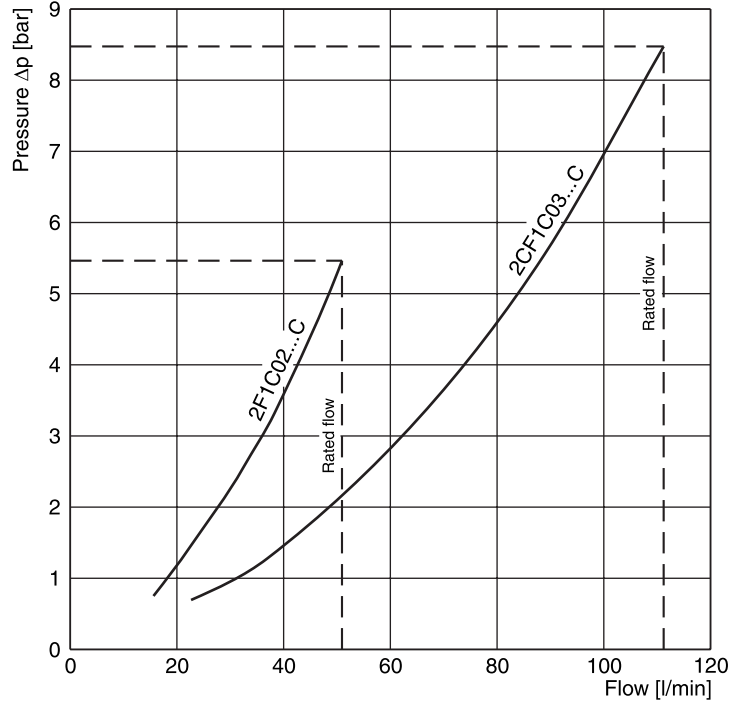

**Minimum pressure difference curves**

**2F1C02**

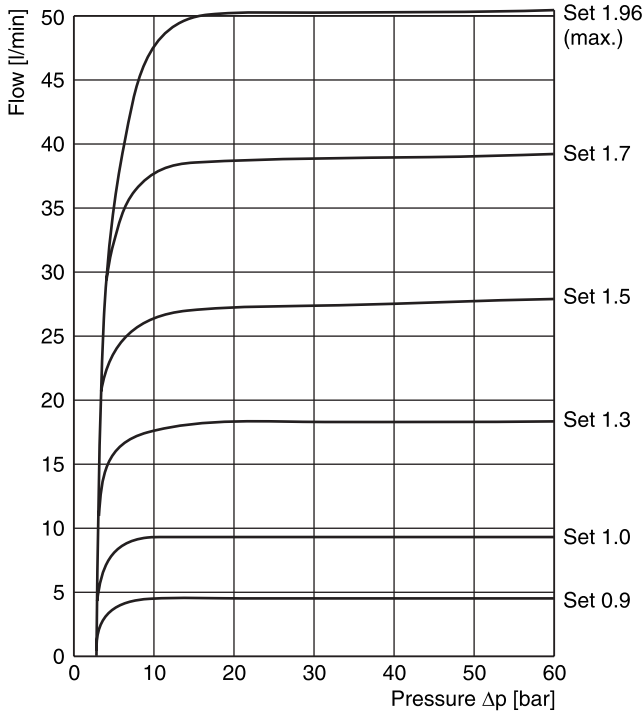

**2F1C03**

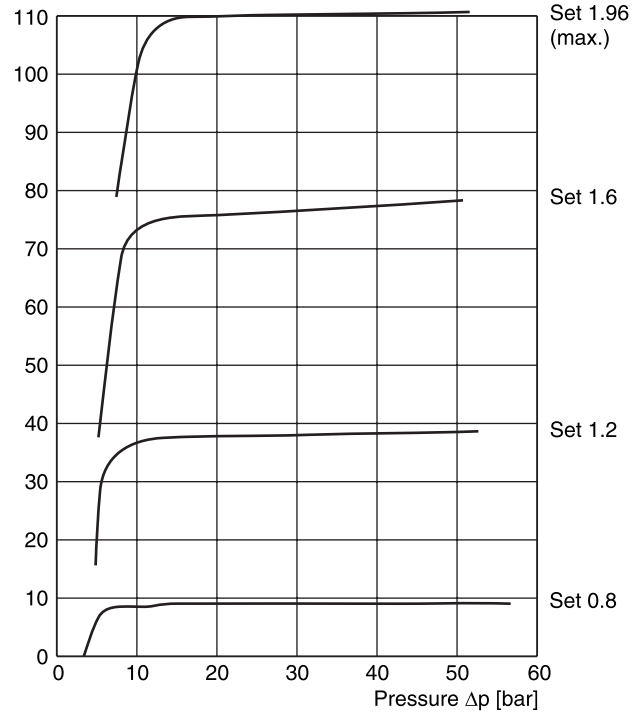

Fluid viscosity 40 cSt at 50°C

2F1C\_UK.INDD CM

**Leakage / pressure curves**

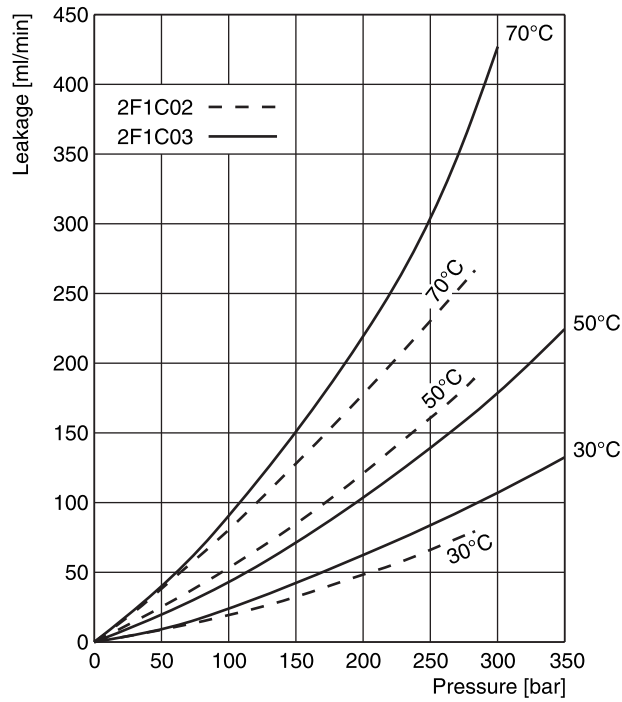

**Flow / temperature curves  
 at 210 bar**

**2F1C02**

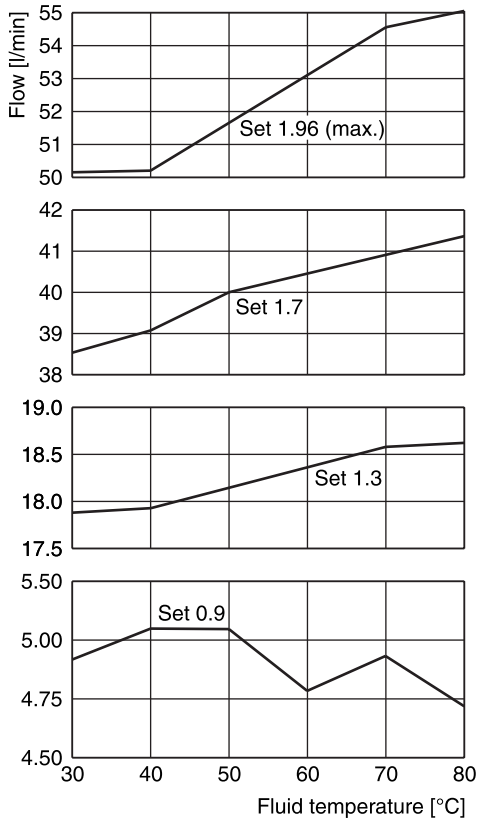

**2F1C03**

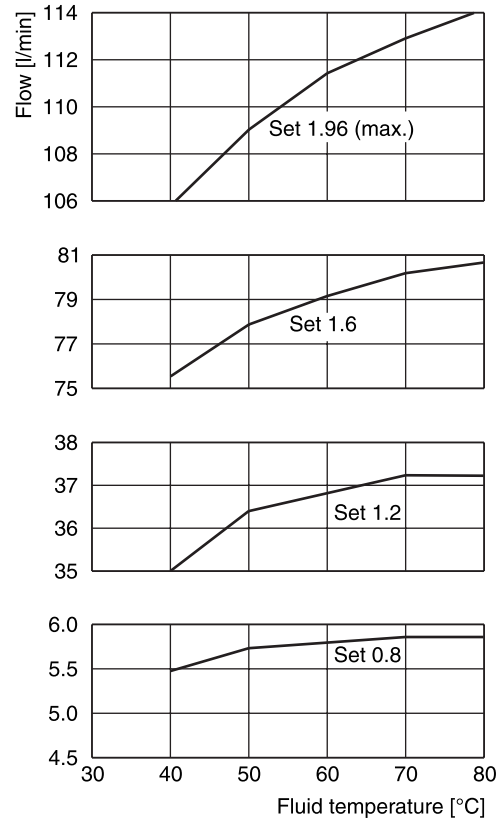

Fluid viscosity 40 cSt at 50°C

2F1C\_UK.INDD CM

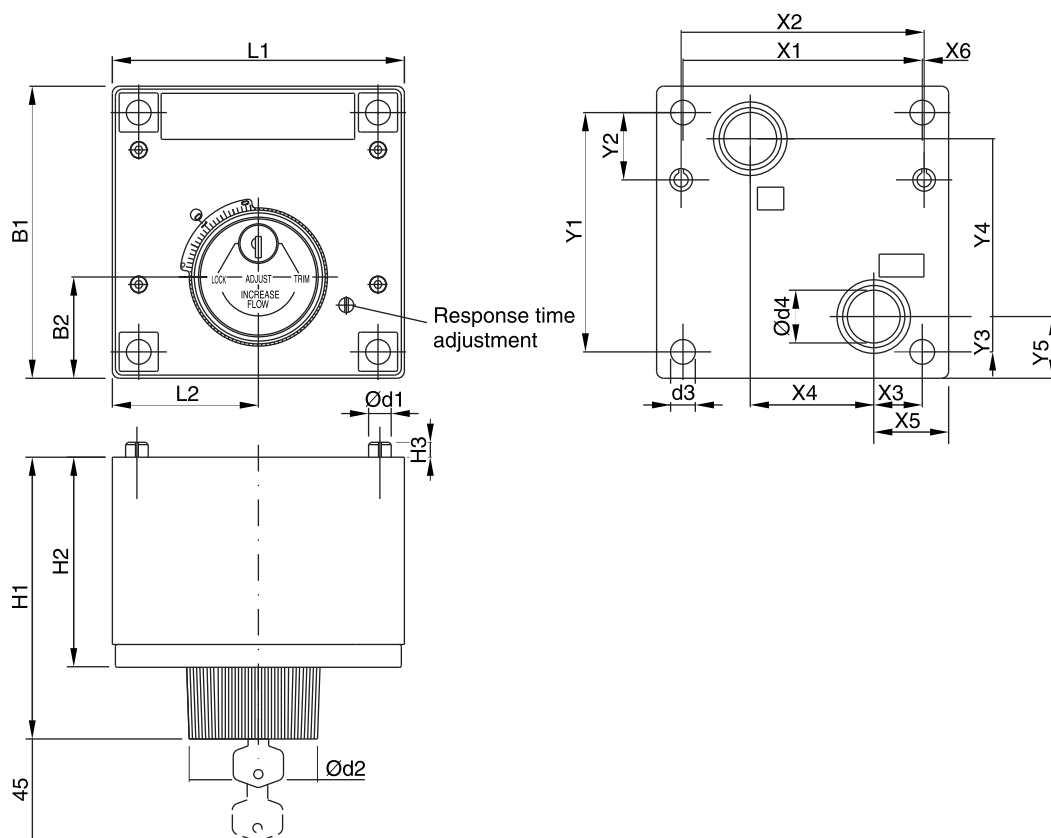

Dimensions



5

Size	ISO-code	x1	x2	x3	x4	x5	x6	y1	y2	y3	y4	y5
02	6263-AM-07-2-A	76.2	79.4	9.5	44.5	19	-	82.5	23.8	30.2	41.3	39.7
03	6263-AK-06-2-A	101.6	103.2	20.6	52.4	31.8	0.8	101.6	28.6	15.1	75.4	26.2

Size	ISO-code	B1	B2	H1	H2	H3	L1	L2	d1	d2	d3	d4
02	6263-AM-07-2-A	101.6	38.1	119.6	87.4	6.4	95.2	47.6	6.4	57.2	8.7	14.2
03	6263-AK-06-2-A	123.8	42.9	121.4	89.2	6.4	123.8	61.9	9.5	57.2	10.5	22.4

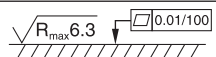
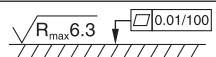
NG	ISO-code	Bolt kit -  DIN912 12.9		 Kit	Surface finish
02	6263-AM-07-2-A	BK-700-70842-8 4xM8x100	31.8 Nm ±15%	on request	
03	6263-AK-06-2-A	BK395 4xM10x100	63 Nm ±15%	on request	

## Characteristics

The proportional flow control valve DUR\*L06 can be used for remote electrical adjustment of the speed of a hydraulic actuator (cylinder, hydraulic motor). The load independence (load-sensing) of the flow is achieved through a built-in pressure compensator. Temperature independence is given to a large extent by the metering orifice. This improves hysteresis and repeatability. The valve is equipped with a built-in check valve for the return flow.

For meter-in and meter-out control of an actuator a rectifier plate can be used. See 'Accessories' at the end of this chapter.

The 2 way proportional flow control valves are fitted with the metering orifice, the metering piston and reset spring, as well as the pressure compensator with differential spring.

### Function

When solenoid current is applied, the metering spool opens against the reset spring and the flow is regulated by the pressure compensating spool to port B.

With the aid of the pressure compensating spool, the pressure drop is held constant on the metering window. Thus pressure load changes are compensated, and the oil flow remains constant.

In combination with the digital electronic module PCD00A-400 the valve parameters can be saved changed and duplicated.

## 2 Way Proportional Flow Control Valve Series DUR\*L06

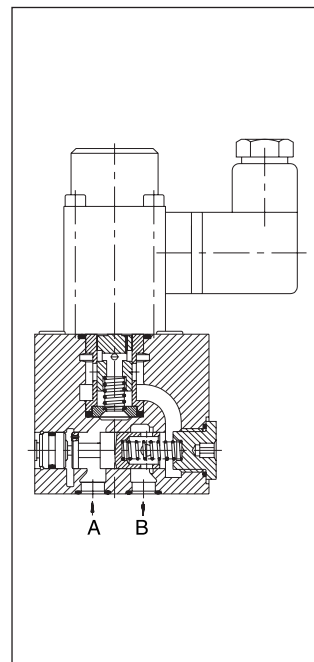
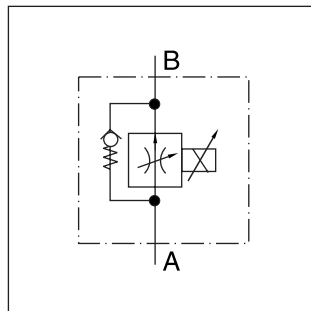

### Technical features

- Low hysteresis
- High reproducibility
- Load-independent oil flow
- Bypass check valve
- Mounting pattern to ISO 6263

### Technical data

Design		Electrically adjustable orifice valve with load sensing
Mounting type		Subplate NG06, Interface DIN 24340, ISO, CETOP
Mounting position		unrestricted, preferably horizontal
Ambient temperature	[°C]	-20°C...+50
Weight	[kg]	1.6
Type of voltage	[V]	24
Max. control current	[mA]	680
Coil resistance	[Ohm]	24
Duty cycle		100% ED
Solenoid connection		Connector as per EN 175301-803
Protection class		IP 65 in accordance with EH60529 (plugged and mounted)
Amplifier module		PCD00A-400
Operating pressure	[bar]	Max. 210
Fluid temperature	[°C]	+20 up to max. +70
Viscosity range	[cSt] / [mm²/s]	12...230
Filtration		$\beta_{10} \geq 75$ (10 $\mu\text{m}$ filtering) Standard
Min. pressure difference	[bar]	DUR 1.6/3.2: 3; DUR 6.3/12: 5; DUR 18: 8
Hysteresis at $Q_{nom}$	[%]	6
Hysteresis at $Q \leq 20\% \cdot Q_{nom}$	[%]	6
Repeatability at $\Delta U_{set} = 5V$	[%]	2

Ordering Code / Performance Curves

Ordering code

**DUR**

2 way flow control valve with bypass check valvel

**Nominal flow**

Nominal flow

**L**

Linear solenoid

**06**

Size NG06

**P**

Progressive performance curve

**K**

Solenoid

**Seal**

Seal

**Design series**

(not required for ordering)

Code	Flow [l/min]
1.6	1.6
3.2	3.2
6.3	6.3
12.0	12.0
18.0	18.0

Code	Seal
A	NBR
1	FPM

5

Seal kits

NBR	FPM
SK-DUR***L	SK-DUR***L FPM

Performance curves

DUR 1.6 L 06 PK\*

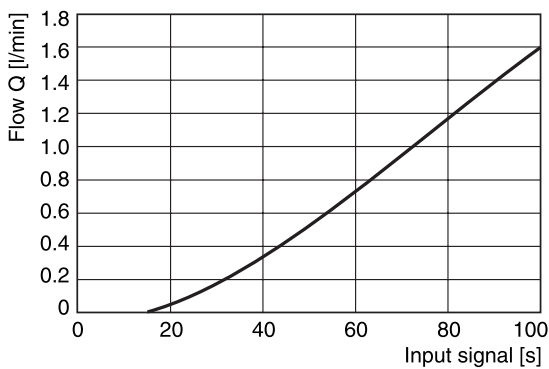

DUR 12 L 06 PK\* / DUR 18 L 06 PK\*

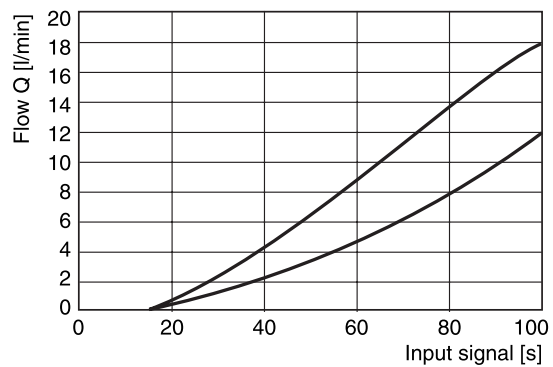

DUR 3.2 L 06 PK\* / DUR 6.3 L 06 PK\*

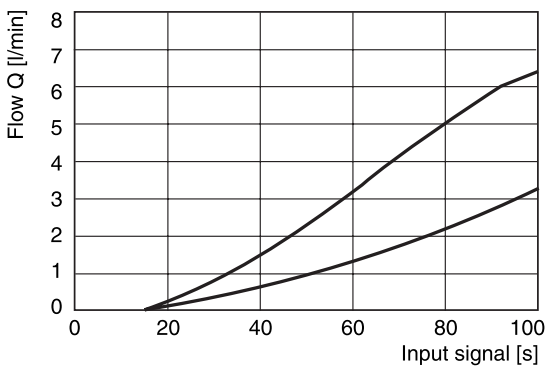

**Dimensions**

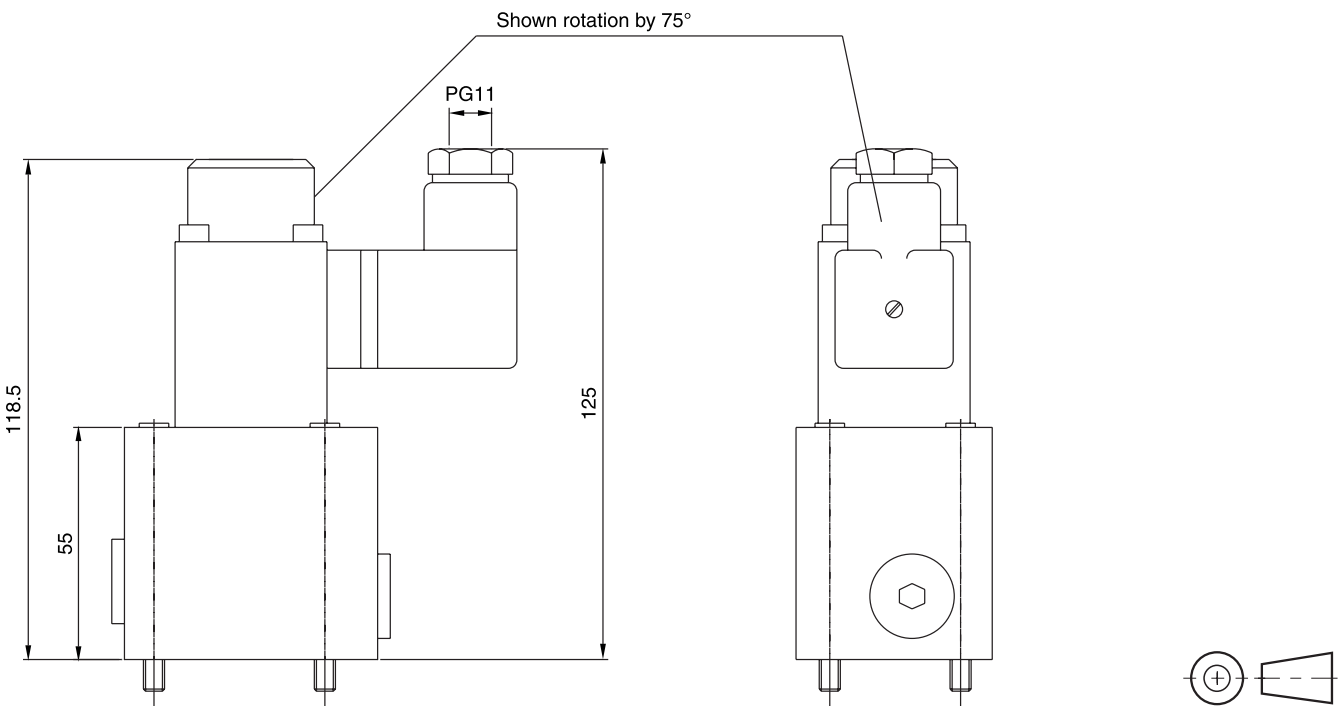
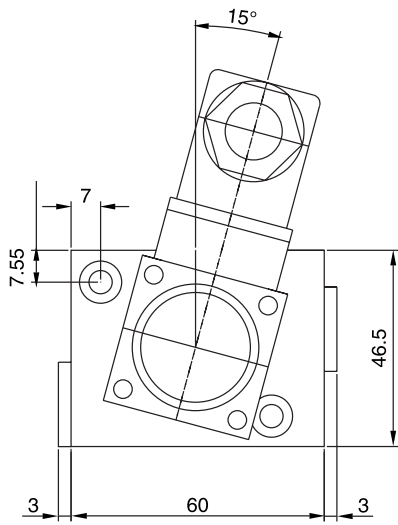
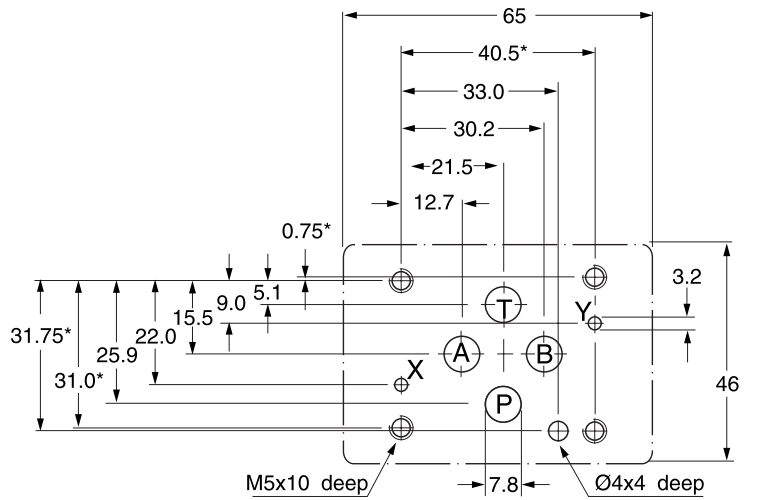

**5**



Description	Threaded cable joint	Body colour coding	Figures switching	Order no.
Plug DIN 43650, design type AF, protection class IP 65 Voltages up to 250 V	PG 9	black, B grey, A	Fig. 1	<b>5001710</b> <b>5001711</b>
	PG11	black, B	Fig. 1 grey, A	<b>5001716*</b> <b>5001717*</b>
Plug with LED insert 24 V	PG11	black, B grey, A	Fig.1 and Fig. 3	<b>5001571</b> <b>5001572</b>
Plug with LED insert 110 V	PG11	black, B grey, A	Fig.1 and Fig. 4	<b>5001573</b> <b>5001574</b>
Plug with LED insert 220 V	PG11	black, B grey, A	Fig.1 and Fig. 4	<b>5001575</b> <b>5001576</b>
Plug with LED insert 24V and suppressing circuitry	PG11	black, B grey, A	Fig.1 and Fig. 5	<b>5001708</b> <b>5001709</b>
Plug with rectifier. Rectifier with 4 silicon diodes in bridge circuit. Varistor in alternating current side to protect the diodes against power peaks	PG11	black, B grey, A	Fig.1 and Fig. 6	<b>5001737</b> <b>5001738</b>
Plug with pull relief and translucent cover	PG11	black, B grey, A	Fig. 2	<b>5001723</b> <b>5001724</b>
Application with bridge rectifier suitable for 5001723 and 5001724	—	—	Fig. 2 and Fig. 7	<b>5001727</b>
Application with bridge rectifier and lamp suitable for 5001723 and 5001724	—	—	Fig. 2 and Fig. 8	<b>5001734</b>

\* If not ordered otherwise, valves with code P are supplied with these connectors.

**5**

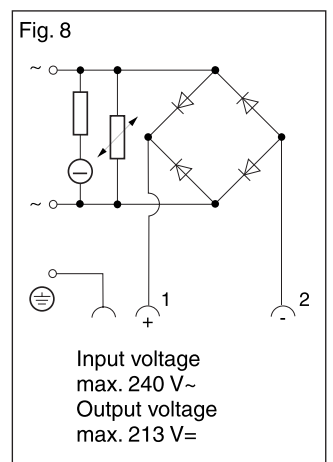
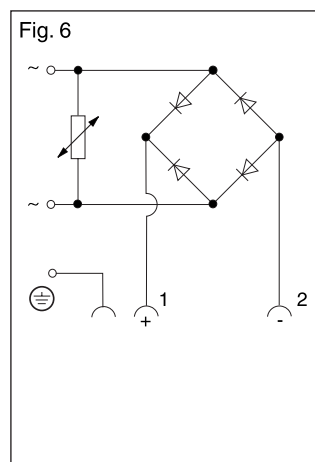
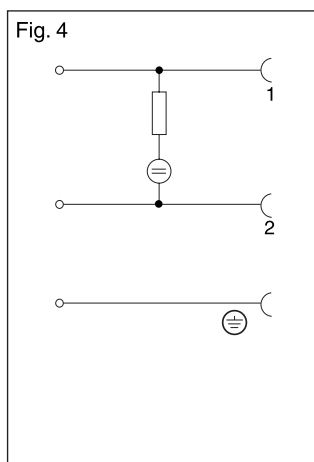
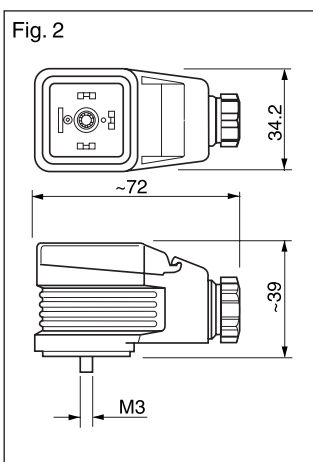
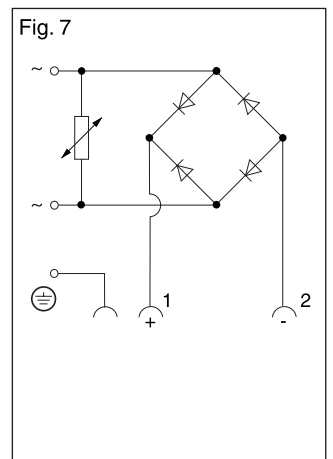
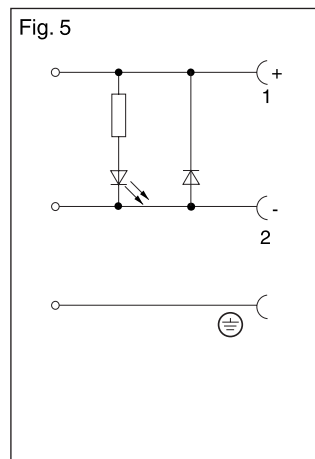
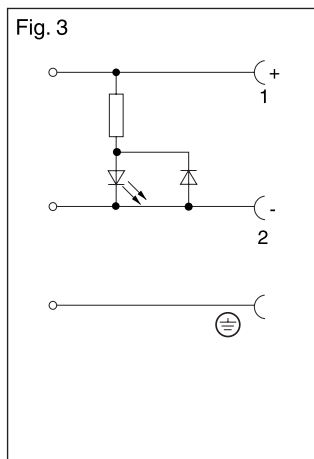
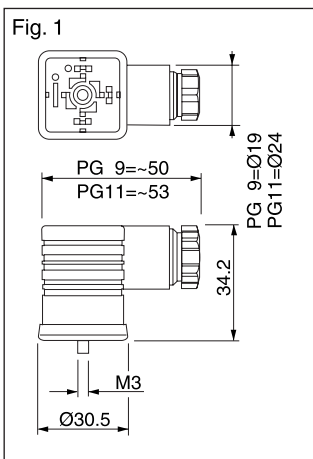

**Mounting sets (MVK) for panel installation**

Description	M (mm)	Valve
MVK 2	15	MV 200
MVK 4	20	MV 400, MV 620
MVK 6	23	MV 600, MV 820
MVK 8	29	MV 800, MV 1020
MVK 12	36	MV 1200
MVK 12	36	MV 1600

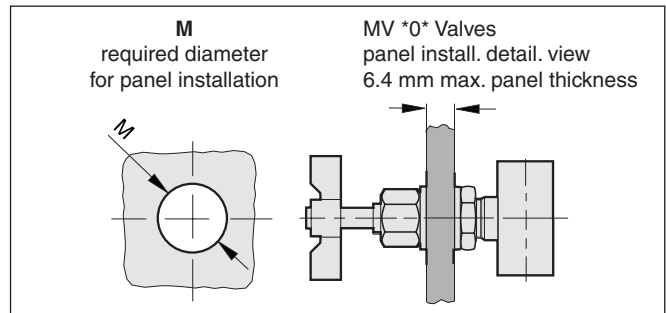

**Drills for MVI valves**

Material	Valve sizes and ordering code		
	400	600	800 and 1200
Cutting alloy	SE 1062	SE 567	on request
Steel	SE 1063	SE 1061	

5

**Sandwich rectifier plate for the model GFG 2**

If a 2 way flow control valve is used in combination with a rectifier plate the valve can be used for meter-in and meter-out flow control of an actuator.

**Design**

The intermediate rectifier plate is designed with 4 identical, symmetrically arranged check valves. Thus the differential pressure is the same in both flow directions.

**Δp/Q Performance curve**

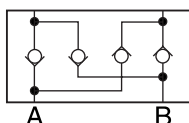
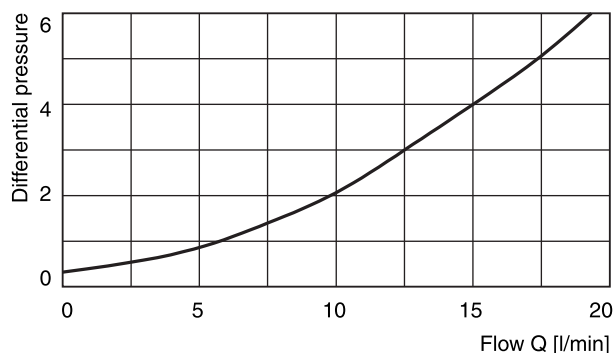

**Dimensions**

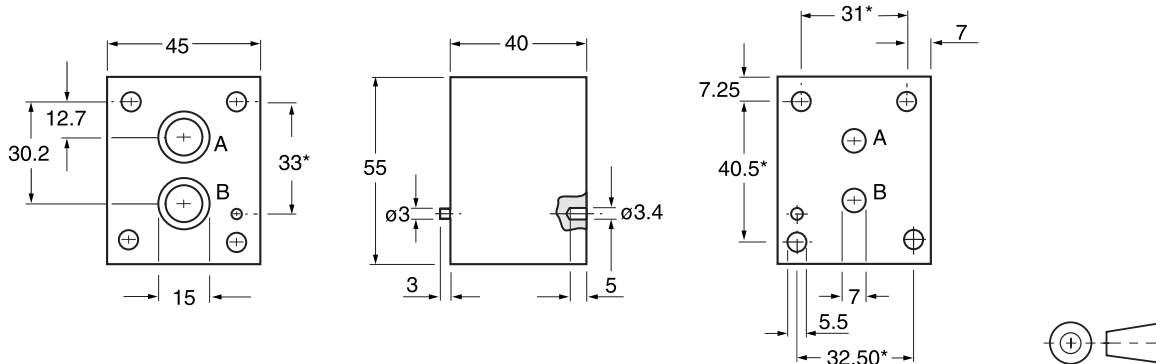

Dimension tolerances  
 \* : ± 0.1mm  
 others : ± 0.2 mm  
 holes and silhouette of  
 valve body : untoleranced dimension

**Ordering code:** HR OA 06 C

**O-ring for sealing the connecting surface**  
 (not included)

Connections	Dimensions	required units
A, B	12 x 1.5	2

